

NOTES: UNLESS OTHERWISE SPECIFIED

- OA1- IS THE THEORETICAL OPTIC AXIS OF THE FIRST OPTIC SURFACE.
- OA2- IS THE THEORETICAL OPTIC AXIS OF THE SECOND OPTIC SURFACE.
- ASPHERIC SURFACES ARE DEFINED BY:

$$z(r) = \frac{r^2/R_c}{1 + \sqrt{1 - (1 + K)(r/R_c)^2}} + \sum_i A_{2i}r^{2i}$$

WHERE: r = RADIAL DISTANCE FROM VERTEX IN mm

4. SURFACE DEFINITIONS:

	SURFACE 1	SURFACE 2
TYPE	ASPHERE	ASPHERE
SHAPE	CX	CX
CA	∅0.40	∅0.70
R _C	2.364322	-0.445025
K	0.000000	-0.056327
A ₂	0.000000E0	0.000000E0
A ₄	7.501852E0	1.121325E0
A ₆	-1.536240E2	3.936434E0
A ₈	7.323558E2	1.852195E1
A ₁₀	0.000000E0	0.000000E0
A ₁₂	0.000000E0	0.000000E0
A ₁₄	0.000000E0	0.000000E0
A ₁₆	0.000000E0	0.000000E0

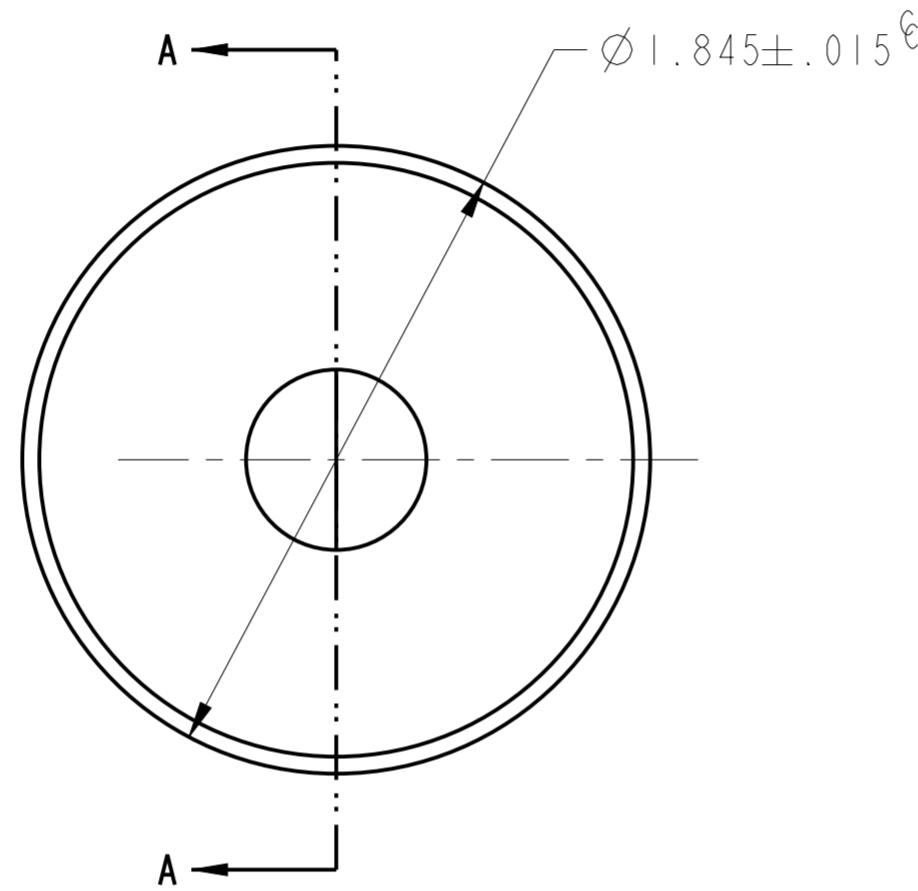

5. NOMINAL DESIGN PARAMETERS.

DESIGN WAVELENGTH	1310 nm
WD1/WD2	0.3 mm/2.9 mm
NA1/NA2	0.5/0.1
E.F.L.	0.5mm ± 1.0%

- FEATURES IDENTIFIED AS Ⓢ ARE CRITICAL CHARACTERISTICS. CRITICAL CHARACTERISTICS ARE GUARANTEED IN PRODUCTION.
- THIS ELEMENT MUST MEET THE SCRATCH/DIG REQUIREMENTS ACROSS THE FULL CLEAR APERTURES INDICATED, BOTH SIDES, PER LIGHTPATH PWI INS-8.2-05P6.Ⓢ
-00: S/D: 40/20
- THIS ELEMENT IS USED AS A COLLIMATING LENS.
WAVEFRONT ERROR: @ 100% < 0.05 WAVES RMS @ 658.0 nm;
@ 50% APERTURE < 0.25 WAVES P-V
PER LIGHTPATH PWI INS-8.2-13.Ⓢ



	RADIUS ERROR	IRREGULARITY
S1	±0.276 mm	< 329.0 nm PV
S2	±0.003 mm	< 109.7 nm RMS

REVISION HISTORY				
REV	DCO	DESCRIPTION	DATE	INITIALS
A	3508	INITIAL RELEASE	06/11/13	JL
B	6306	UNOBSOLETE	10/02/20	CC

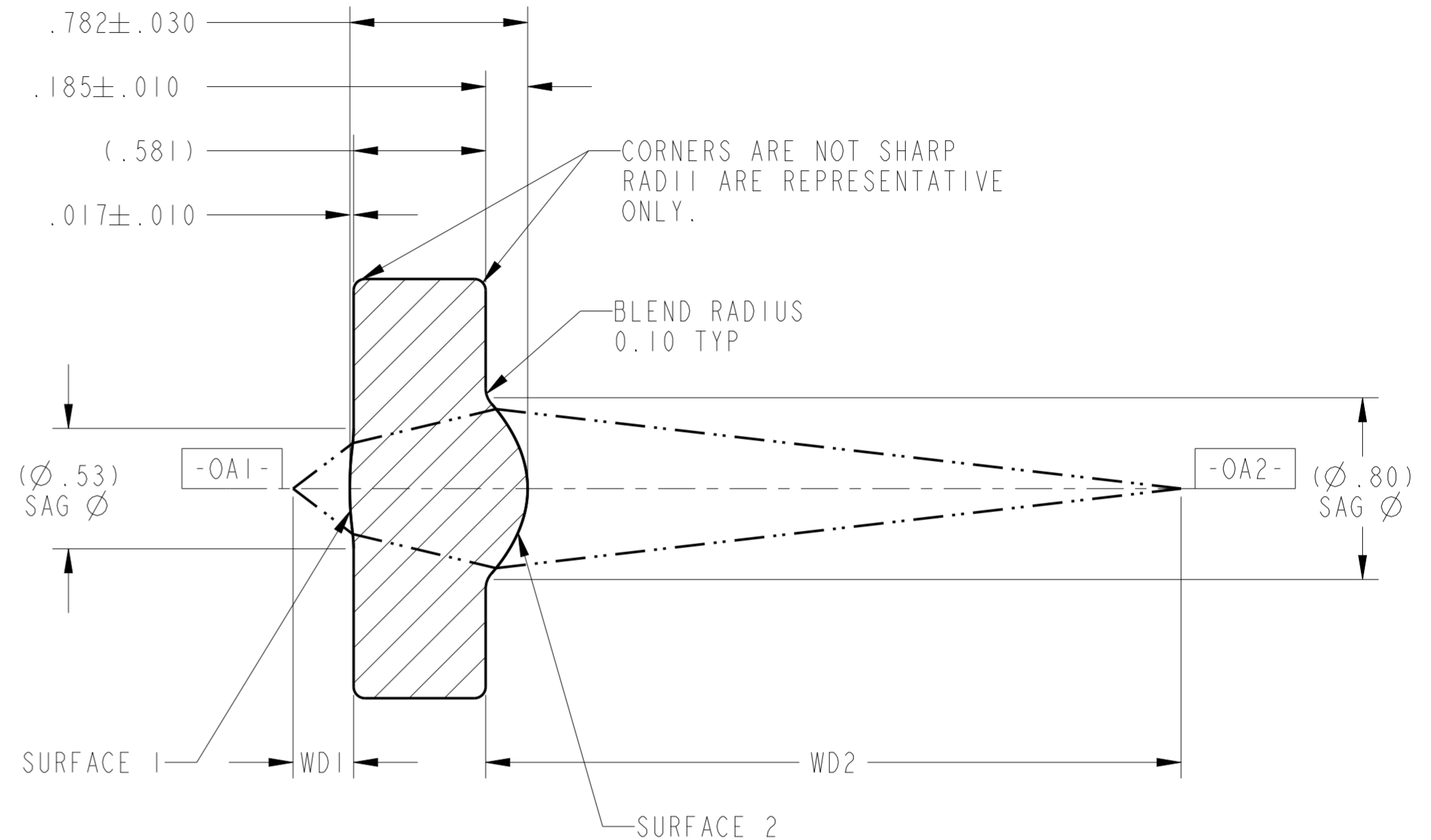

SECTION A-A

UNLESS OTHERWISE SPECIFIED DIMENSIONS ARE IN MM. DECIMAL TOLERANCES ARE: .X ± 0.25 .XX ± 0.10 .XXX ± 0.025 .XXXX ± 0.013 ANGLES: ± 0.5°		 2603 CHALLENGER TECH CT. SUITE 100 ORLANDO, FL 32826		PROPRIETARY INFORMATION THIS DOCUMENT CONTAINS PROPRIETARY INFORMATION OF LIGHTPATH TECHNOLOGIES AND IS NOT TO BE DISCLOSED OR REPRODUCED IN WHOLE OR PART, OR USED FOR MANUFACTURING FOR ANYONE OTHER THAN LIGHTPATH TECHNOLOGIES WITHOUT ITS WRITTEN CONSENT. NO RIGHT IS GRANTED TO DISCLOSE OR USE ANY INFORMATION CONTAINED IN SAID DOCUMENT.	
DRAWN CC\ORL		TITLE LENS CODE 355465			
MATERIAL D-ZLAF52LA(m)	SIZE A2	DWG NO 0355465	REV B		
SOFTWARE Pro/ENGINEER	SCALE: 45.00	THIRD ANGLE PROJECTION	SHEET 1 OF 1		