

NOTES: UNLESS OTHERWISE SPECIFIED

1. **-OA1-** IS THE THEORETICAL OPTIC AXIS OF THE FIRST OPTIC SURFACE.
2. **-OA2-** IS THE THEORETICAL OPTIC AXIS OF THE SECOND OPTIC SURFACE.
3. MATERIAL: D-ZLAF52LA(m)
HOLDER MATERIAL: SF20F-SST
4. ASPHERIC SURFACES ARE DEFINED BY:

$$z(r) = \frac{r^2/R_c}{1 + \sqrt{1 - (1 + K)(r/R_c)^2}} + \sum_i A_{2i}r^{2i}$$

WHERE: Y= RADIAL DISTANCE FROM VERTEX IN mm

5. SURFACE DEFINITIONS:

	SURFACE 1	SURFACE 2
TYPE	ASPHERE	ASPHERE
SHAPE	CX	CX
CA	∅1.24	∅1.24
R _C	1.443899	-1.443899
K	-3.385696	-3.385696
A ₂	0.000000E0	0.000000E0
A ₄	1.860144E-2	-1.860144E-2
A ₆	-7.029784E-2	7.029784E-2
A ₈	8.825543E-2	-8.825543E-2
A ₁₀	-4.324029E-2	4.324029E-2
A ₁₂	0.000000E0	0.000000E0
A ₁₄	0.000000E0	0.000000E0
A ₁₆	0.000000E0	0.000000E0

6. NOMINAL DESIGN PARAMETERS.

DESIGN WAVELENGTH	1300 nm
W.D.	1.174.8 mm
N.A.	0.170.4
E.F.L.	1.1mm ± 1.0%

7. FEATURES IDENTIFIED AS Ⓔ ARE CRITICAL CHARACTERISTICS. CRITICAL CHARACTERISTICS ARE GUARANTEED IN PRODUCTION.
8. THIS ELEMENT MUST MEET THE SCRATCH/DIG REQUIREMENTS ACROSS THE FULL CLEAR APERTURES INDICATED, BOTH SIDES, PER LIGHTPATH PWI INS-8.2-05P6.Ⓔ
-00: S/D: 40/20
9. THIS ELEMENT IS USED AS A COLLIMATING LENS.
WAVEFRONT ERROR: @ 100% APERTURE < 0.145 WAVES RMS @ 632.8nm;
@ 50% APERTURE < 0.270 WAVES P-V
PER LIGHTPATH PWI INS-8.2-13.Ⓔ

REVISION HISTORY				
REV	DCO	DESCRIPTION	DATE	INITIALS
A	2726	INITIAL RELEASE	03/29/11	BAUZ
B	4384	UPDATED FORMAT	12/21/15	PL
C	5249	MATERIAL WAS D-ZLAF52LA(m)	02/02/18	MW

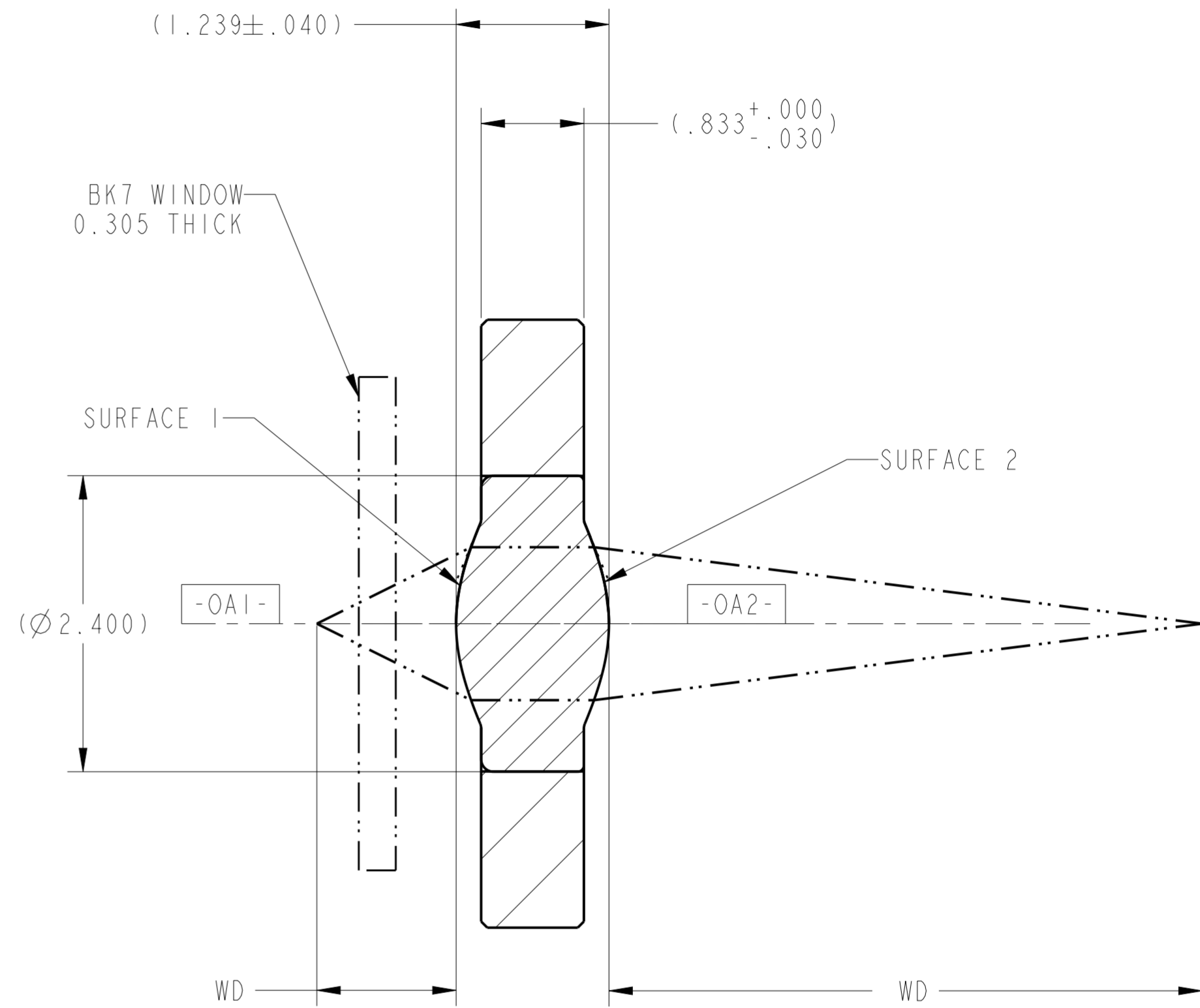
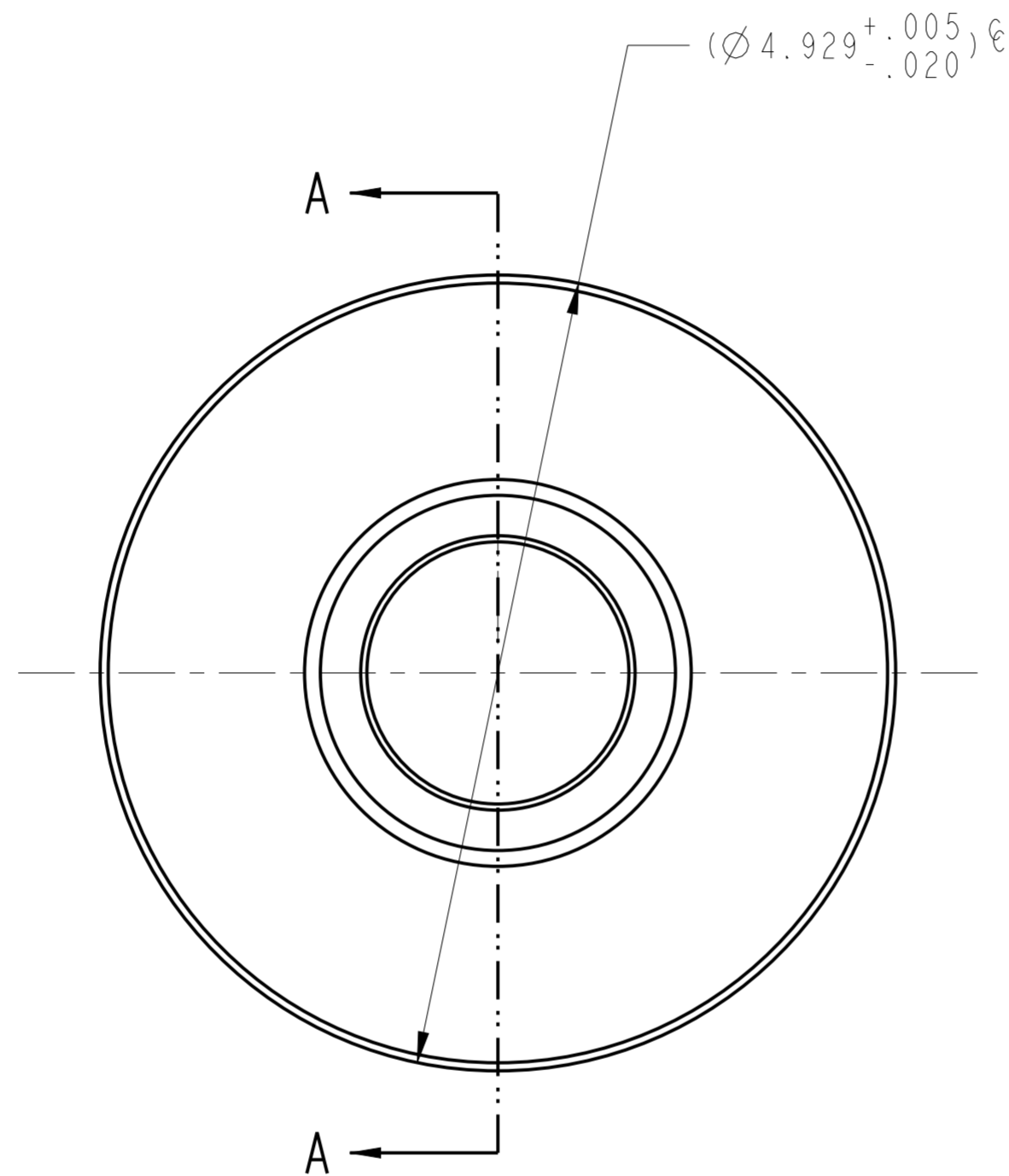

SECTION A-A



UNLESS OTHERWISE SPECIFIED DIMENSIONS ARE IN MM. DECIMAL TOLERANCES ARE: .X ± 0.25 .XX ± 0.10 .XXX ± 0.025 .XXXX ± 0.013 ANGLES: ± 0.5°		LightPath <small>TECHNOLOGIES</small> 2603 CHALLENGER TECH CT., SUITE 100 ORLANDO, FL 32826		PROPRIETARY INFORMATION THIS DOCUMENT CONTAINS PROPRIETARY INFORMATION OF LIGHTPATH TECHNOLOGIES AND IS NOT TO BE DISCLOSED OR REPRODUCED IN WHOLE OR PART, OR USED FOR MANUFACTURING FOR ANYONE OTHER THAN LIGHTPATH TECHNOLOGIES WITHOUT ITS WRITTEN CONSENT. NO RIGHT IS GRANTED TO DISCLOSE OR USE ANY INFORMATION CONTAINED IN SAID DOCUMENT.	
DRAWN BAUZ\ORL		TITLE LENS CODE 355201			
MATERIAL SEE NOTES		SIZE A2	DWG NO 0355201	REV C	
SOFTWARE Pro/ENGINEER		SCALE: 25.00	THIRD ANGLE PROJECTION	SHEET 1 OF 1	